



for a greener tomorrow



MITSUBISHI ELECTRIC

Changes for the Better

FACTORY AUTOMATION

# INVERTER FR-A800 Plus

New Product RELEASE

No.15-11E

The optimum functions for roll to roll applications are added.

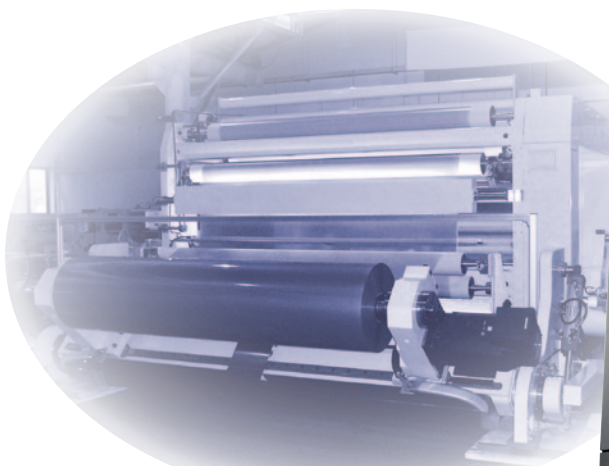

# A800 Plus



for Roll to Roll



**WARNING** Risk of injury and electric shock  
 ▲ Read the manual and follow the safety instructions before use.  
 ▲ Look from top and side 10 minutes before removing the cover.  
 ▲ Ensure proper earth connection.  
 ▲ Fireproof risk of fire.  
 ▲ Mount the inverter on a non-combustible surface.

**WARNING** Il y a un risque de se faire mal et de recevoir une décharge électrique  
 ▲ Avant de retirer le capot, attendez 10 minutes avant de retirer le capot.  
 ▲ Assurez la bonne connexion à la terre.  
 ▲ Montez le convertisseur sur une surface non-combustible.

**注意** 人身の怪我や感電の危険があります  
 ▲ 取扱説明書を読み、安全指示に従ってください。  
 ▲ カバーを取り除く前に、上と側面から10分間待機してください。  
 ▲ 接地を適切に行ってください。  
 ▲ 火災の危険があります。  
 ▲ 燃焼性のない面に設置してください。

**注意** 人身の怪我や感電の危険があります  
 ▲ 取扱説明書を読み、安全指示に従ってください。  
 ▲ カバーを取り除く前に、上と側面から10分間待機してください。  
 ▲ 接地を適切に行ってください。  
 ▲ 火災の危険があります。  
 ▲ 燃焼性のない面に設置してください。



GOOD DESIGN AWARD 2014

FR-A800 Plus series **2nd**

# Release of the new roll to roll dedicated inverter, FR-A800-R2R

The FR-A800-R2R inverter has various dedicated functions such as winding diameter calculation, providing stable winding/unwinding control independently.

**A800 Plus**  
for Roll to Roll

## A800 Plus

A new lineup of dedicated inverters for specialized fields are born! Plus! The optimum functions for each dedicated field are added to the already high performance and high functionality FR-A800 series inverter.

Roll to roll dedicated model with functions optimum for winding/unwinding

### System simplification

Stable winding/unwinding can be achieved by the inverter alone.

### Wide range of applications

The inverter can be used in various systems.

### Easy startup and adjustment

Parameters can be used for mechanical adjustment according to applications.

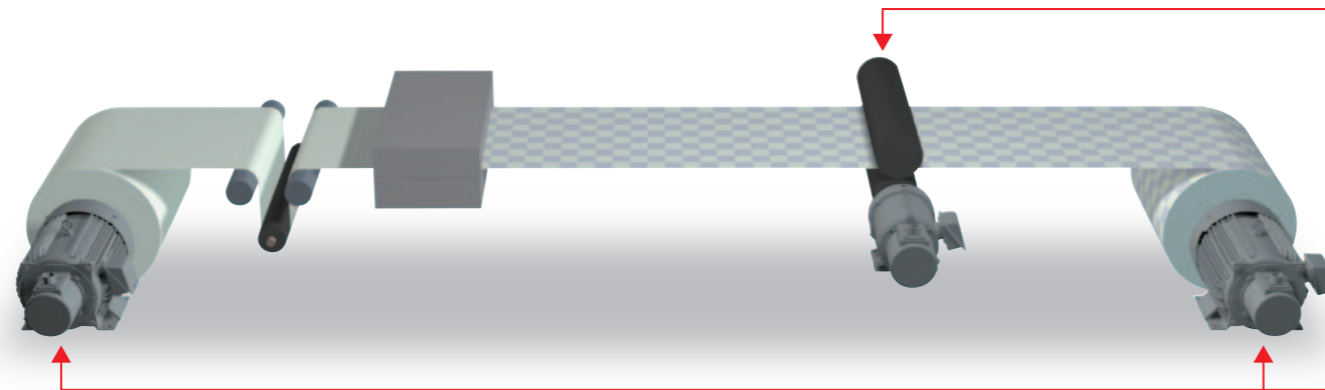

### Winding/unwinding shaft

The tension is kept constant by accommodating the change in the winding diameter. Calculations are made for the acceleration/deceleration torque (inertia compensation) at a speed change and the mechanical loss torque.

### Reference shaft

The line speed is controlled by driving the reference shaft.

## A variety of roll to roll dedicated functions are supporting various systems.

### Winding diameter calculation

The present winding diameter for the winding/unwinding shaft is calculated from the actual line speed or the actual motor speed.

### Winding diameter calculation function selection

The winding diameter calculation method can be selected in order to improve the tension control performance.

- Actual line speed calculation method  
The winding diameter is calculated from the line speed and the main speed (actual motor speed).

$$D = \frac{V}{\pi \times n \times Z}$$

- Thickness calculation method  
The material thickness is added up to find the overall winding diameter.  
 $D = \text{Initial diameter} \pm 2 \times d \times N \times Z$

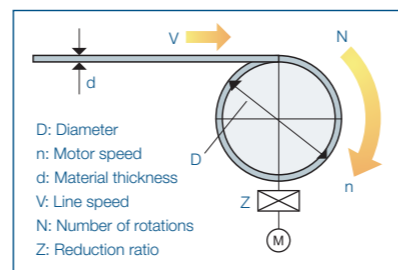

### Dancer feedback speed control

PID control is performed based on the feedback of the detected dancer roll position. Stable control can be achieved in combination with the winding diameter calculation.

### Speed control proportional gain compensation

By adjusting the speed control proportional gain, response improvement is achievable according to the winding diameter.

### Tension PI gain tuning

By automatically adjusting the tension PI gain, time required for adjustment is significantly cut down. Anyone can start the system easily.

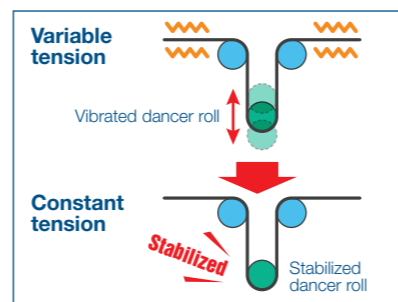

### Tension sensorless torque control

The output torque of a motor is controlled so that the tension applied to a material is constant by calculating the winding diameter of a roll.

### Mechanical loss compensation function

The tension applied to the material is maintained constant by raising a commanded torque to compensate mechanical loss caused by factors such as friction on the dancer roll or winding/unwinding shaft.

### Inertia compensation function

During acceleration/deceleration, the tension applied to the material is maintained constant by adjusting the variable tension on the winding and unwinding sides.

### Taper function

By adjusting the tension on the workpiece, it is possible to avoid imperfections such as wrinkles or deformation caused by the increase in diameter.

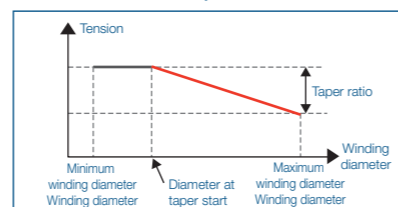

### Application example Wire drawing machine

#### Dancer feedback speed control

The FR-A800-R2R is useful for winding in the wire drawing machine. High-speed winding is offered for high-inertia loads.

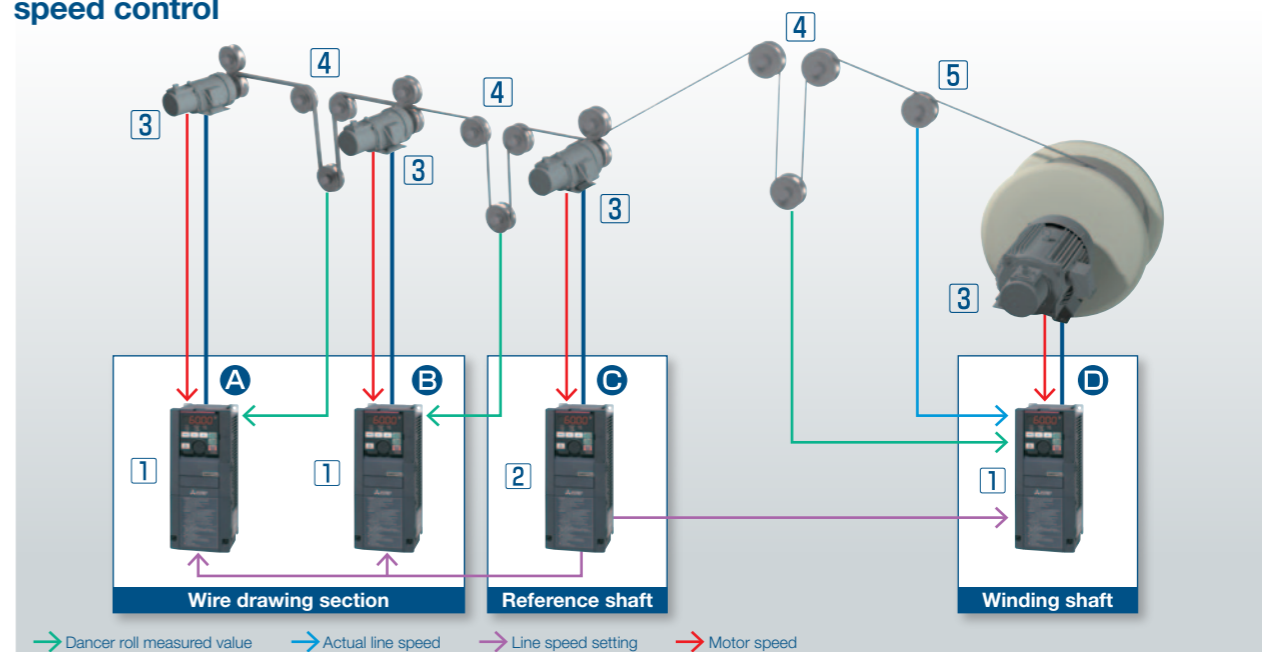

The wire drawing section pulls the wire at a constant speed to make the wire thinner. For the winding shaft, the inverter provides dancer feedback speed control to keep the dancer roll position, achieving constant tension winding. In addition, using the winding diameter calculation function, the circumferential speed of the winding bobbin is kept constant.

- 1 Inverter FR-A800-R2R (with the FR-ABAP\*1 installed)
- 2 Inverter FR-A800-R2R (with the FR-ABAP\*1 and FR-ABAZ\*2 installed)
- 3 Encoder-equipped motor SF-FR-SC
- 4 Dancer roll
- 5 Speed detector

The products in the parentheses are plug-in options.

\*1 Used for vector control. \*2 Used for the line speed output.

### Relevant functions

Dancer feedback speed control  
A B D

Winding diameter calculation function  
Speed control proportional gain compensation

Tension PI gain tuning

# LINEUP

## • Standard model

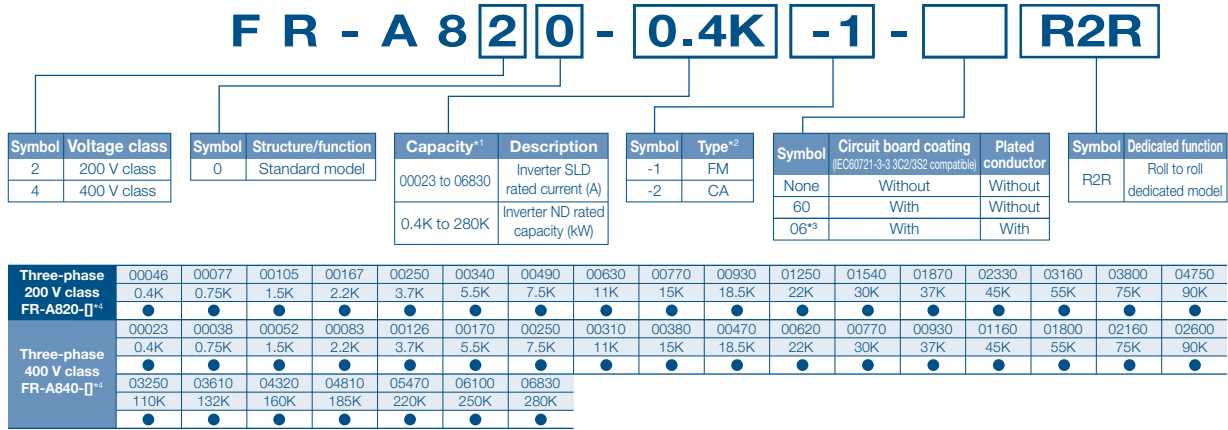

## • Separated converter type

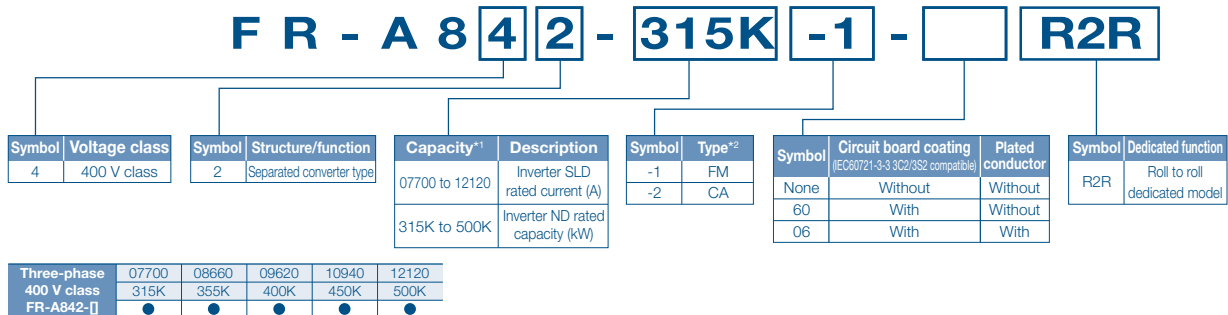

\*1 Models can be alternatively indicated with the inverter rated current (SLD rating).

\*2 Specification differs by the type as follows.

\*3 Available for the 5.5K or higher.

\*4 For the 75K or higher inverter, or whenever a 75 kW or higher motor is used, always connect a DC reactor (FR-HEL), which is available as an option.

Type	Monitor output	Initial setting			
		Built-in EMC filter	Control logic	Rated frequency	Pr.19 Base frequency voltage
FM (terminal FM equipped model)	Terminal FM: pulse train output Terminal AM: analog voltage output (0 to ±10VDC)	OFF	Sink logic	60 Hz	9999 (same as the power supply voltage)
CA (terminal CA equipped model)	Terminal CA: analog current output (0 to 20mADC) Terminal AM: analog voltage output (0 to ±10VDC)	ON	Source logic	50 Hz	8888 (95% of the power supply voltage)

**Release schedule**

Now available

**MITSUBISHI ELECTRIC CORPORATION**

HEAD OFFICE: TOKYO BLDG., 2-7-3, MARUNOUCHI, CHIYODA-KU, TOKYO 100-8310, JAPAN